

Incremental ϕ 80mm Hollow Shaft Type

Diameter ϕ 80mm Hollow shaft type Incremental Rotary encoder

■ Features

- External diameter ϕ 80mm, Inner diameter of shaft ϕ 30mm, ϕ 32mm (Customizable)
- Able to install directly at motor or machinery without coupling
- Power supply : 5VDC, 12–24VDC \pm 5%
- Various output types

⚠ Please read "Caution for your safety" in operation manual before using.



■ Ordering information

E80H	30	3200	3	N	24	
Series	Shaft diameter	Pulse/1 Revolution	Output phase	Output	Power supply	Cable
Diameter ϕ 80mm, hollow shaft type	ϕ 30mm ϕ 32mm	60, 100, 360, 500, 512, 1024, 3200	3 : A, B, Z 6 : A, \bar{A} , B, \bar{B} , Z, \bar{Z}	T : Totem pole output N : NPN open collector output V : Voltage output L : Line driver output(*)	5 : 5VDC \pm 5% 24 : 12–24VDC \pm 5%	No mark: Normal type (*) C: Cable outgoing connector type

⇒ Shaft inside diameter ϕ 32mm is customizable.

*The power of Line driver is only for 5VDC

*Cable length : 250mm

■ Specifications

Item	Diameter ϕ 80mm hollow shaft type of Incremental rotary encoder		
Resolution (P/R)	(Note1) 60, 100, 360, 500, 512, 1024, 3200		
Electrical specification	Output phase	A, B, Z phase (Line driver output A, \bar{A} , B, \bar{B} , Z, \bar{Z} phase)	
	Phase difference of output	Phase difference between A and B : $\frac{T}{4} \pm \frac{T}{8}$ (T=1 cycle of A phase)	
	Control output	Totem pole output	• Low ⇒ Load current: Max. 30mA, Residual voltage : Max. 0.4VDC • High ⇒ Load current: Max. 10mA, Output voltage (Power supply 5VDC): Min. (Power supply–2.0) VDC, Output voltage (Power supply 12–24VDC): Min. (Power supply–3.0) VDC
		NPN open collector output	Load current : Max. 30mA, Residual voltage : Max. 0.4VDC
		Voltage output	Load current : Max. 10mA, Residual voltage : Max. 0.4VDC
		Line driver output	• Low ⇒ Load current : Max. 20mA, Residual : Max. 0.5VDC • High ⇒ Load current : Max. –20mA, Output voltage : Min. 2.5VDC
	Response time (Rise/Fall)	Totem pole output	Max. 1 μ s
		NPN open collector output	Max. 1 μ s
		Voltage output	Max. 1 μ s
		Line driver output	Max. 0.5 μ s
	Max. Response frequency	200kHz	
	Power supply	• 5VDC \pm 5% (Ripple P–P: Max. 5%) • 12–24VDC \pm 5% (Ripple P–P: Max. 5%)	
	Current consumption	Max. 80mA (disconnection of the load), Line driver output: Max. 50mA (disconnection of the load)	
	Insulation resistance	Min. 100M Ω (at 500VDC mega between all terminals and case)	
Dielectric strength	750VAC 50/60Hz for 1 minute (Between all terminals and case)		
Connection	Cable outgoing type, 200mm cable outgoing connector type		
Mechanical specification	Starting torque	Max. 200gf • cm (0.02N • m)	
	Rotor inertia	Max. 800g • cm ² (8 \times 10 ^{–5} kg • m ²)	
	Shaft loading	Radial : 5kgf, Thrust : 2.5kgf	
	Max. allowable revolution	(Note2) 3600rpm	
Vibration	1.5mm amplitude at frequency of 10 ~ 55Hz in each of X, Y, Z directions for 2 hours		
Shock	Max. 75G		
Ambient temperature	–10 ~ 70 $^{\circ}$ C (at non-freezing status), Storage : –25 ~ 85 $^{\circ}$ C		
Ambient humidity	35~85%RH, Storage : 35~90%RH		
Protection	IP50 (IEC standard)		
Cable	ϕ 5mm, 5P, Length : 2m, Shield cable (Line driver output : ϕ 5mm, 8P)		
Accessory	Spring bracket		
Unit weight	Approx. 560g		
Approval	CE (Except for Line driver output)		

* **(Note1)** Not indicated type is customizable.

* **(Note2)** Max. allowable revolution \geq Max. response revolution [Max. response revolution (rpm) = $\frac{\text{Max. response frequency}}{\text{Resolution}} \times 60 \text{ sec}$]

(A) Counter

(B) Timer

(C) Temp. controller

(D) Power controller

(E) Panel meter

(F) Tacho/Speed/Pulse meter

(G) Display unit

(H) Sensor controller

(I) Switching power supply

(J) Proximity sensor

(K) Photo electric sensor

(L) Pressure sensor

(M) Rotary encoder

(N) Stepping motor & Driver & Controller

(O) Graphic panel

(P) Field network device

(Q) Production stoppage models & replacement

E80H Series

Control output diagram

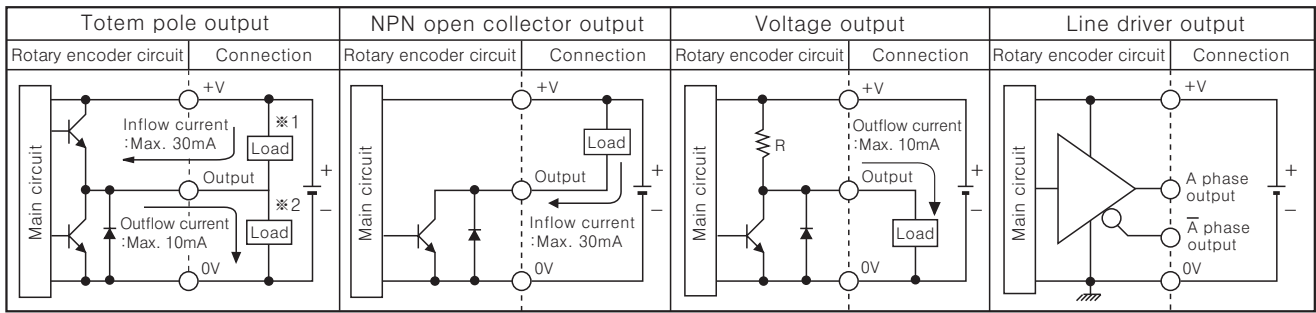

※ Totem pole output type can be used for NPN open collector output type(※1) or Voltage output type(※2).
 ※ All output circuits of A, B, Z phase is same. (Line driver output is for A, \bar{A} , B, \bar{B} , Z, \bar{Z})

Output waveform

● Totem pole output / NPN open collector output / Voltage output

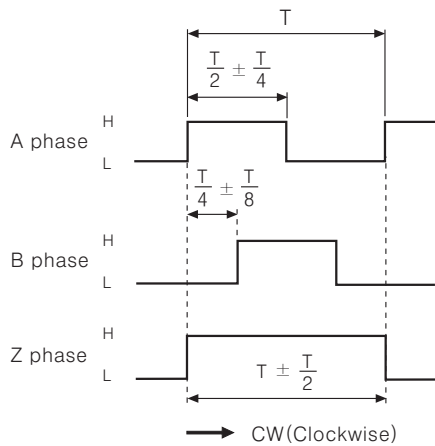

※ CW : As viewed from the shaft

● Line driver output

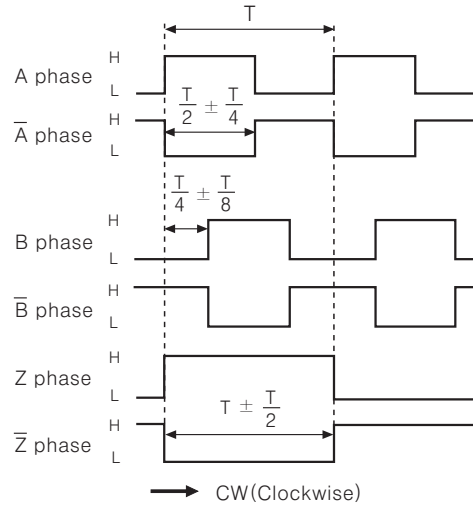

Connections

Normal type

● Totem pole output / NPN open collector output / Voltage output

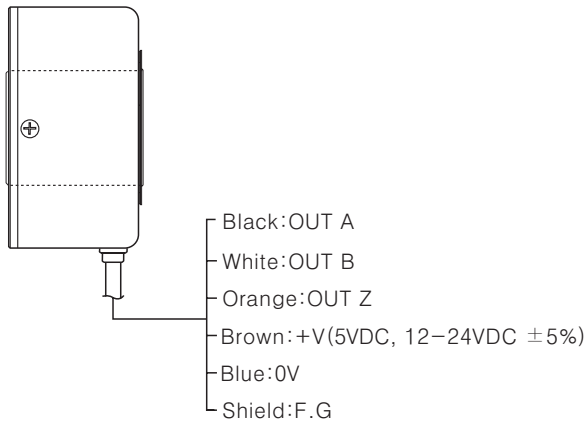

※ Unused wires must be insulated.

※ The metal case and shield cable should be grounded(F.G).

● Line driver output

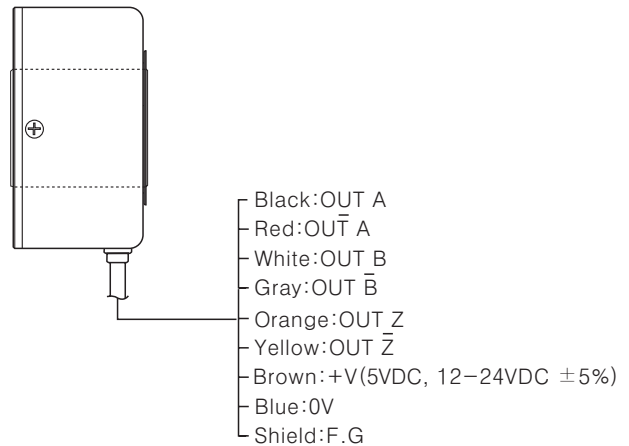

Incremental ϕ 80mm Hollow Shaft Type

■ Connection

■ Cable outgoing connector type

- Totem pole output / NPN open collector output / Voltage output

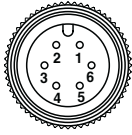

- Line driver output



Totem pole output NPN open collector output Voltage output			Line driver output		
Pin No	Function	Cable color	Pin No	Function	Cable color
①	OUT A	Black	①	OUT A	Black
②	OUT B	White	②	OUT \bar{A}	Red
③	OUT Z	Orange	③	+V	Brown
④	+V	Brown	④	GND	Blue
⑤	GND	Blue	⑤	OUT B	White
⑥	F.G	Shield	⑥	OUT \bar{B}	Gray
			⑦	OUT Z	Orange
			⑧	OUT \bar{Z}	Yellow
			⑨	F.G	Shield

*F.G(Field Ground):It should be grounded separately.

■ Dimensions

■ Normal type

- Inner diameter of shaft(Standard)

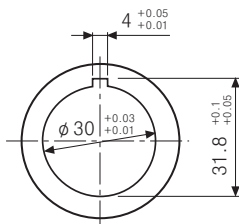

- Inner diameter of shaft(Customizable)

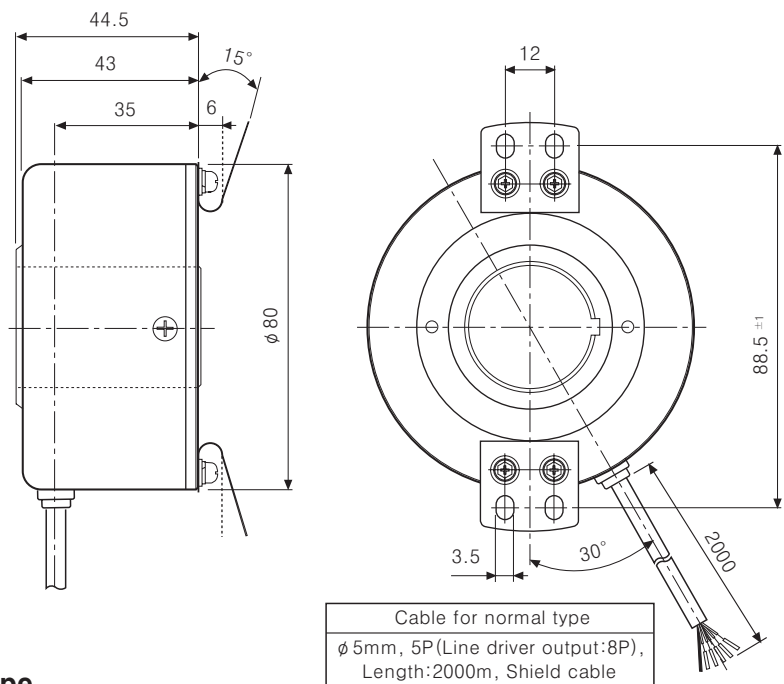
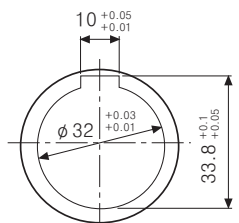

■ Cable outgoing connector type

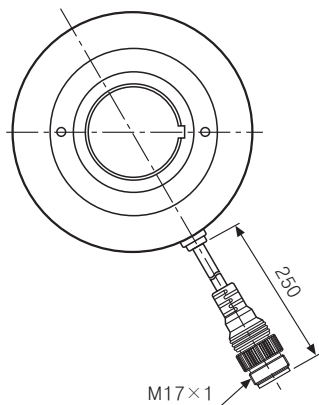

• Bracket

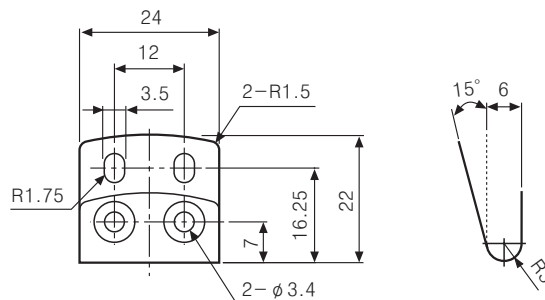

*Connector cable is customizable and see M-57 for specifications.

(A)
Counter

(B)
Timer

(C)
Temp.
controller

(D)
Power
controller

(E)
Panel
meter

(F)
Tacho/
Speed/
Pulse
meter

(G)
Display
unit

(H)
Sensor
controller

(I)
Switching
power
supply

(J)
Proximity
sensor

(K)
Photo
electric
sensor

(L)
Pressure
sensor

(M)
Rotary
encoder

(N)
Stepping
motor &
Driver &
Controller

(O)
Graphic
panel

(P)
Field
network
device

(Q)
Production
stoppage
models &
replacement