

East Coast Sensors

Base Metal thermocouple & protection tube TX2 Series

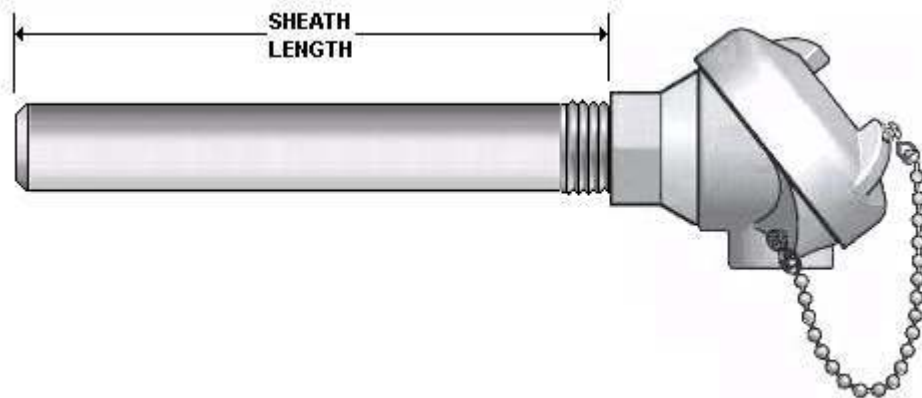

Ordering Information Part Number

① TX2	② Calibration	③ Wire Gauge	④ Protection tube material	⑤ Protection tube size	⑥ Sheath Length (Whole In.)	⑦ Sheath Length (fractional in.)	⑧ Junction - Weld Type	⑨ Connection Head Style
TX2								

② Calibration	
J	J
K	K
T	T
E	E
N	N

③ Wire Gauge	
A	8 gauge
C	14 gauge
E	20 gauge

④ Protection Tube Material	
15	446 SS
16	Pure Nickel
17	Inconel
18	304 stainless steel
19	310 stainless steel
20	316 stainless steel
21	Silicon Carbide
22	Mullite
23	Alumina
24	Metal Ceramic
25	Carbon Steel
26	Tercod
27	Cast Alloy
28	Cast Iron with Tap
29	330 stainless steel
30	Hexaloy
31	Cast-T
32	Refractory Coated
33	Incoloy 800
34	Hastelloy C 276

⑤ Protection Tube Size	
A	1/4"NPT
B	1/2"NPT
C	3/4"NPT
D	1"NPT
E	1-3/4"OD
F	3/8"OD
G	11/16"OD
H	3/4"OD
J	7/8"OD
K	1"OD
L	1/8"NPT
M	3/8"NPT
N	1/2"OD
P	7MM OD
R	1/4"OD

⑥ Sheath Length (whole in.)	
002"-060"	Specify in Inches
Note	For other configurations not shown contact factory

⑦ Sheath Length (fractional in.)	
A	0
B	1/8"
C	1/4"
D	3/8"
E	1/2"
F	5/8"
G	3/4"
H	7/8"

⑧ Junction - Weld Type	
M	Butt weld
N	Twisted weld
S	Dual junction - Butt weld

⑨ Connection Head Style	
A	Cast Aluminum (standard)
B	Small cast Aluminum
C	Flip top head cast aluminum
D	Cast steel
E	Stainless Steel
F	Cast Iron
G	Polypropylene
H	Explosion proof cast aluminum

⑩ Special features (optional)	
Note	See next page

⑪ Attached Fitting (optional)	
Note	See next page

⑫ Insertion length (whole in.)	
Note	See next page

⑬ Insertion Length (frac. in.)	
Note	See next page

See next page for optional attached fittings & special features (Fields 9,10,11, & 12)

East Coast Sensors

Base metal thermocouple & protection tube

Attached fittings & special features
TX2 Series

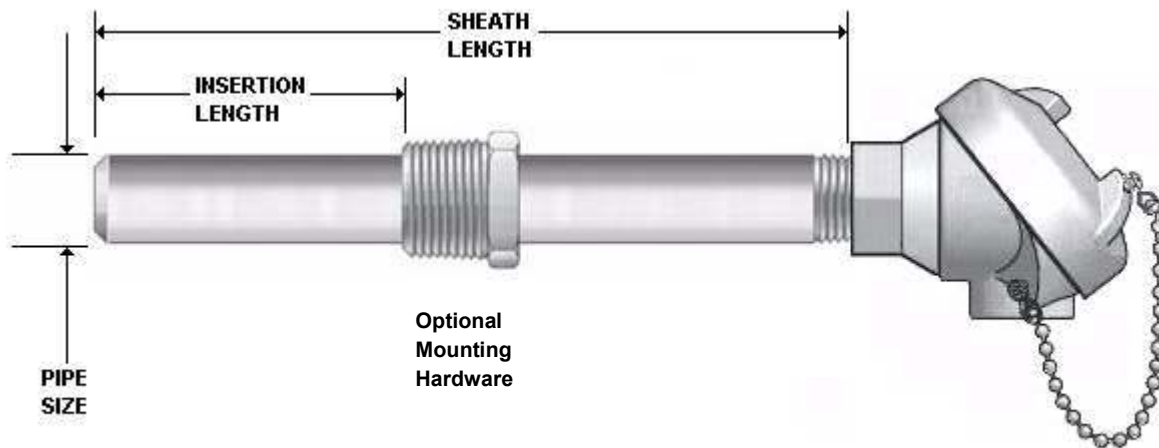

Continue part number from previous page

Ordering Information Part Number

⑩ Special features (Optional)	⑪ Attached Fitting	⑫ Insertion Length (whole in.)	⑬ Insertion Length (Frac.in.)

⑩	Special features (Optional)
Note	Leave blank for none
B01	Ajax Bend
B02	Open both ends
B03	Lot Certification
B05	Individual Cert.
B06	Schedule 80
B07	Dual/Lot cert.
B08	Butt weld/Lot cert.
B09	Dual Butt weld/lot cert.
X	Special contact factory

⑪	Attached Fitting or Hardware
Note	Leave blank for none
A	Adjustable Flange
B	1/2"NPT Stainless Steel
C	3/4"NPT Stainless Steel
D	1"NPT Stainless Steel
E	1-1/4"NPT Stainless Steel
F	1-1/2"NPT Stainless Steel
G	1/2"NPT Steel
H	3/4"NPT Steel
J	1"NPT Steel
K	1-1/4"NPT Steel
L	1-1/2"NPT Steel
M	Tapered Plug
P	Hot Junction Cup
Note	For other configurations not shown contact factory

⑫	Insertion Length (in.) (optional)
001"-059"	Specify in Inches
Note	See pg. ____ for attached fitting location information

⑬	Insertion Length (fractional in.)
A	0
B	1/8"
C	1/4"
D	3/8"
E	1/2"
F	5/8"
G	3/4"
H	7/8"