



BLD4Q



The BLD2Q, 4Q and 8Q Blade linear LED luminaires provides controlled illumination for general and task lighting designed for the harsh environments found in food processing and heavy manufacturing facilities. The Blade luminaire utilizes high efficiency LED light sources that is reduce maintenance and lower energy costs yielding a faster return on investment. Our fixtures are designed to withstand the demands for agricultural environments, including harsh daily wash downs.

These high quality durable fixtures are used in food and beverage processing, meat and poultry processing, livestock agricultural facilities, heavy industrial, and manufacturing facilities. Employing appropriate lighting for live stock farms can lead to healthier, more productive animals. Installing quality LED Lighting which meets the demands of food and beverage processing generates positive results for employees and the organization as a whole. Higher light levels improve safety and employee morale, which positively impacts productivity.

- 50 to 200W, 7500 to 30,000 lumens 4K or 5K CCT
- Medium or wide optics, Polycarbonate or optional Acrylic lens
- Certified to UL 1598, wet location
- IP66 Ingress rated water and dust tight.
- NSF2 Food splash zone rated; pressure wash up to 1600 PSI
- Integral Emergency Battery Backup
- 2FT, 4FT, 8FT lengths, aircraft cable or chain hung
- Integral Motion Sensor
- 120-277VAC, 50/60Hz IP67 Driver, 347-480V optional

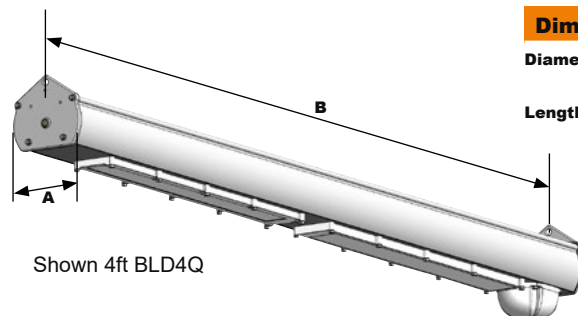

Shown 4ft BLD4Q

Dimensions

Diameter (A)	3.35" (85mm)
Length (B)	2' (610mm);
	4' (1219mm);
	8' (2438mm)

Catalog Number: BLD4QM1X100U4KCPW
 4FT Blade, Medium Distribution, 120/277V, 4K, Clear Polycarbonate lens, White Finish
 COMING SOON - AVAILABLE Q1 2023

Preliminary, specifications subject to change. Refer to published specification sheet for most current information.

Rev. 100722