

Distance Sensor

U1RT003

Part Number



- 2 mutually independent switching outputs
- IO-Link version 1.1
- Reflex and through-beam operation mode are possible
- Temperature range: -30...60 °C
- Wireless settings via NFC

These ultrasonic sensors evaluate the sound reflected from the object. They can detect almost any object and are especially well suited for monitoring fill levels of liquids and bulk goods and for detecting transparent objects regardless of the material, state, color or transparency. The measured value can be read out via IO-Link, and the sensor can be optimally adapted to the application. The format allows space-saving installation on conveyor lines. The sensor can be used in reflex mode operation and as an ultrasonic through-beam sensor.



Technical Data

Ultrasonic Data

Working range, reflex sensor	100...1200 mm
Working range, through-beam sensor	1...2000 mm
Reproducibility maximum	5 mm
Linearity Deviation	2 mm
Resolution	1 mm
Ultrasonic Frequency	240 kHz
Opening Angle	< 12 °
Service Life (T = +25 °C)	100000 h
Switching Hysteresis	1 % *

Electrical Data

Supply Voltage	18...30 V DC
Current Consumption (U _b = 24 V)	< 30 mA
Switching frequency, reflex sensor	7 Hz
Switching frequency, through-beam sensor	7 Hz
Response time, reflex sensor	72 ms
Response time, through-beam sensor	72 ms
Temperature Range	-30...60 °C
Number of Switching Outputs	2
Switching Output Voltage Drop	< 2,5 V
Switching Output/Switching Current	100 mA
Synchronous Mode	up to 40 sensors
Short Circuit Protection	yes
Reverse Polarity Protection	yes
Overload Protection	yes
Lockable	yes
Interface	IO-Link V1.1 Smart Sensor Profile/NFC
Data Storage	yes
Protection Class	III

Mechanical Data

Setting Method	Teach-in/IO-Link/NFC
Housing Material	Plastic PBT
Degree of Protection	IP67/IP68
Connection	M12 × 1; 4/5-pin

Safety-relevant Data

MTTFd (EN ISO 13849-1)	1558,4 a
Diagnostic Coverage (DC)	0 %
Mission Time TM (EN ISO 13849-1)	11,42 a

NPN NO

Connection Diagram No.

243

Control Panel No.

A49

Suitable Connection Equipment No.

2

35

Suitable Mounting Technology No.

150

370

* Referring to the switching distance, at least 2 mm.

Complementary Products

IO-Link Master

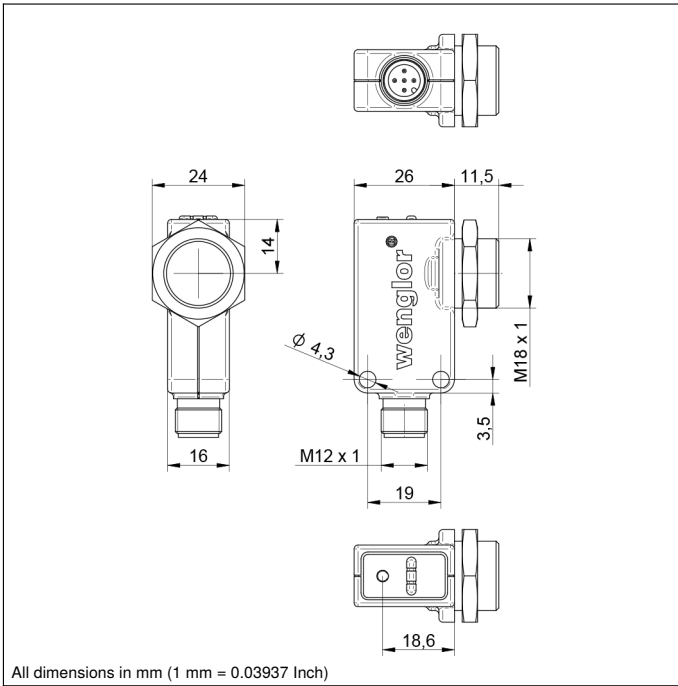

All dimensions in mm (1 mm = 0.03937 Inch)

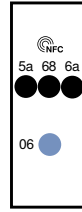
Ctrl. Panel
A 49

- 06 = Teach Button
- 5a = Switching Status Display, O1
- 68 = supply voltage indicator
- 6a = Switching Status Display, O2

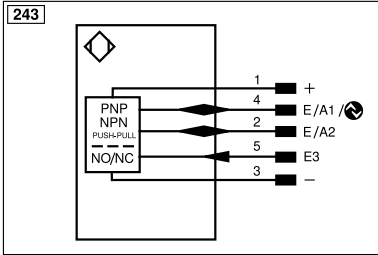

Legend			
+	Supply Voltage +	nc	Not connected
-	Supply Voltage 0 V	U	Test Input
~	Supply Voltage (AC Voltage)	Ū	Test Input inverted
A	Switching Output (NO)	W	Trigger Input
Ā	Switching Output (NC)	W-	Ground for the Trigger Input
V	Contamination/Error Output (NO)	O	Analog Output
ȳ	Contamination/Error Output (NC)	O-	Ground for the Analog Output
E	Input (analog or digital)	BZ	Block Discharge
T	Teach Input	Amv	Valve Output
Z	Time Delay (activation)	a	Valve Control Output +
S	Shielding	b	Valve Control Output 0 V
RxD	Interface Receive Path	SY	Synchronization
TxD	Interface Send Path	SY-	Ground for the Synchronization
RDY	Ready	E+	Receiver-Line
GND	Ground	S+	Emitter-Line
CL	Clock	±	Grounding
E/A	Output/Input programmable	SnR	Switching Distance Reduction
⚡	IO-Link	Rx+/-	Ethernet Receive Path
PoE	Power over Ethernet	Tx+/-	Ethernet Send Path
IN	Safety Input	Bus	Interfaces-Bus A(+)/B(-)
OSSD	Safety Output	La	Emitted Light disengageable
Signal	Signal Output	Mag	Magnet activation
Bl_D+/-	Ethernet Gigabit bidirect. data line (A-D)	RES	Input confirmation
ENo RS422	Encoder 0-pulse 0/0 (TTL)	EDM	Contactor Monitoring
PT	Platinum measuring resistor	ENARs422	Encoder A/A (TTL)
			Wire Colors according to DIN IEC 60757
			BK Black
			BN Brown
			RD Red
			OG Orange
			YE Yellow
			GN Green
			BU Blue
			VT Violet
			GY Grey
			WH White
			PK Pink
			GNYE Green/Yellow

Characteristic response curve

Characteristic curves show the position of the center or the front edge of the measured object (100 × 100 mm plate) at the time of switching. U1RT002/U1RT003

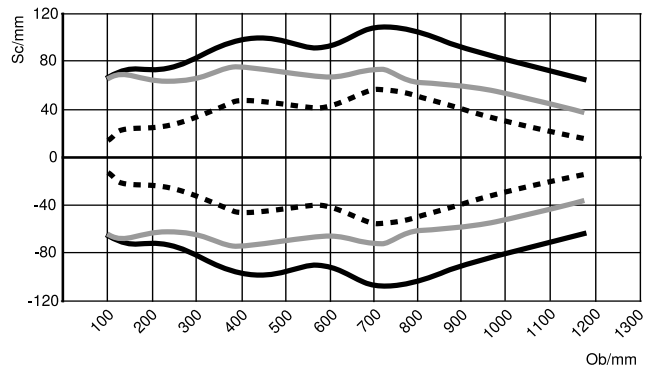

Ob = Object

Sc = Sonic cone width

- Standard sonic cone (center of the measured object)
- - - Extra-narrow sonic cone (center of the measured object)
- · · Standard sonic cone (front edge of the measured object)

