

## JR12

### DESIGN FEATURES

- Replaces size 15 pancake resolver
- Bearing design simplifies encoder attachment
- Incremental resolutions up to 20,000 PPR
- 4, 6 or 8 pole commutation<sup>1</sup>
- Eliminates expensive mounting servo clamps
- Accommodates resolver type ¼" threaded shafts
- High noise immunity
- Cost competitive with modular encoders
- 500 kHz frequency response
- RoHS construction

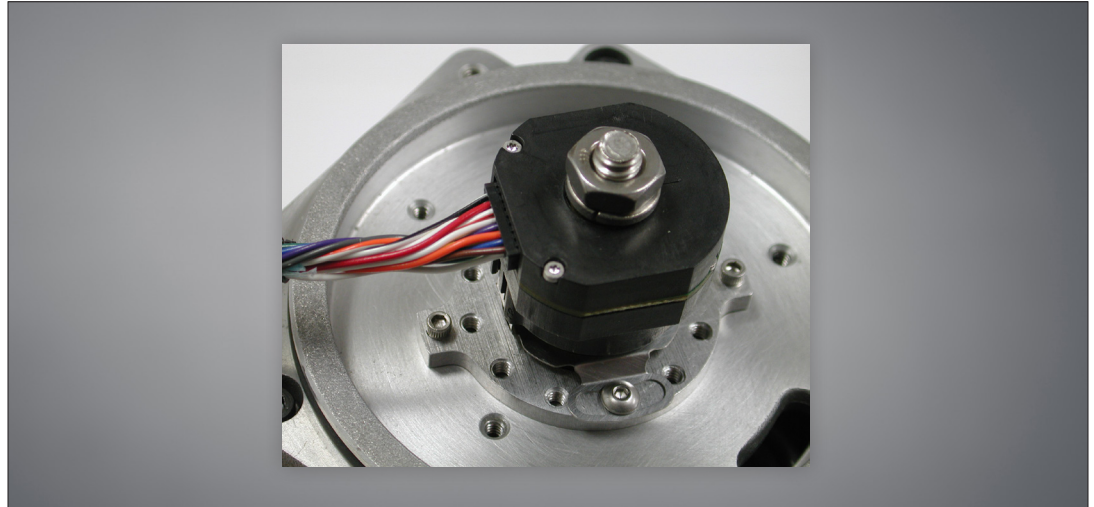

Quantum Devices, Inc. Model JR12 provides an improved feedback solution in applications typically using pancake resolvers with same threaded shaft and jam nut mounting. With an overall height of less than one inch and the stability of a bearing encoder design, the model JR12 can provide significant performance upgrades in applications limited by traditional resolvers or modular encoder solutions. Output options consist of a quadrature with index pulse and three-phase commutation. A flexible member allows for much greater tail shaft run out and TIR than can be tolerated by modular encoder designs, plus the mounting flange eliminates the need for expensive servo mounting clips.

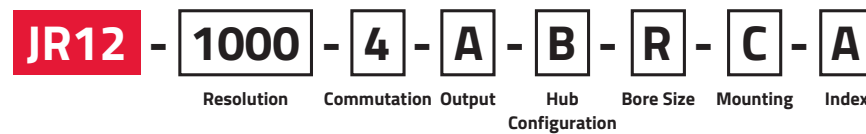

#### Configuration Options:

Resolution <sup>1</sup>	Commutation <sup>1</sup>	Output <sup>1</sup>	Hub Configuration	Bore Size	Mounting	Index
24 <sup>2</sup> , 256, 360, 500, 512, 1000, 1024, 1250, 2000, 2048, 2500, 4000, 4096, 5000, 8192, 10000, 16384, 20000	0 = No Comm 4 = 4 Pole 6 = 6 Pole 8 = 8 Pole	A = Line Driver B = Line Driver ABZ / Open Collector UVW	B = Hole in Cover	R = 0.250"	C = 1.280"	A = 90° gated to A & B

Quantum Devices, Inc.  
112 Orbison St., P.O. Box 100  
Barneveld, WI 53507  
(608) 924-3000  
qd-sales@quantumdev.com

Note:  
1.) Consult factory for configuration options not shown (e.g. resolution, commutation, output, etc.)  
2.) 24 PPR only available with No Comm (Commutation option 0)

**ISO 9001**  
CERT. NO. FM 52711

## OUTPUT WAVEFORMS

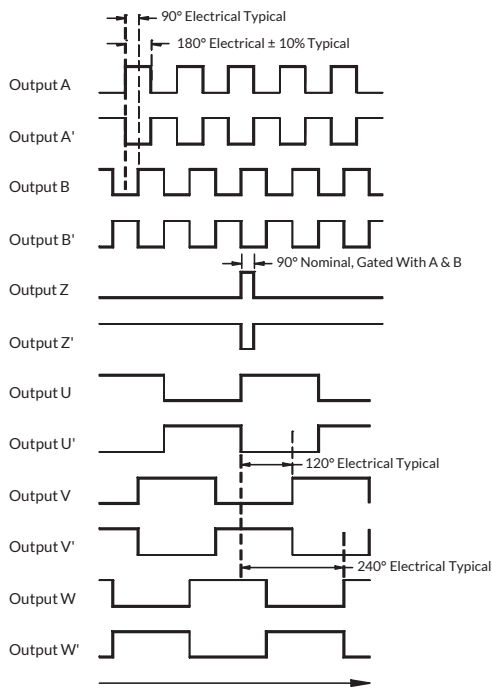

Clockwise Shaft Rotation as Viewed Looking at the Encoder Face (see figure below)

**Note:** Relationship of Z signals to U, V, W signals is not to scale. A & B signals have no relationship to U, V, W signals.

CW Rotation for Output Waveforms

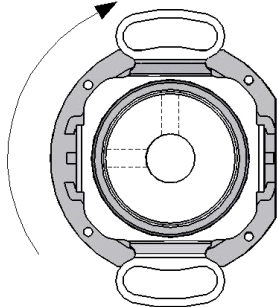

## ELECTRICAL SPECIFICATIONS

Input Voltage	5 VDC $\pm$ 5%
Input Current Requirements	65 mA typical, 100 mA max plus interface loads
Input Ripple	2% peak to peak @ 5 VDC
Output Circuits	A = 26C31 line driver (RS-422 or single-ended TTL) B = ABZ 26C31 line driver, UVW open collector (no U' V' W')
Incremental Output Format	Quadrature with A leading B for CW rotation Index pulse true over A and B high
Max Operating Frequency	500 kHz
Symmetry	180° electrical $\pm$ 10% typical
Minimum Edge Separation	<4000 PPR = 54° electrical $\geq$ 4000 PPR = 45° electrical
Commutation Format	Three phase 4, 6 or 8 poles (other pole counts upon request)
Commutation Accuracy	$\pm$ 1° mechanical
Z Channel to U Channel	$\pm$ 1° mechanical

## ENVIRONMENTAL SPECIFICATIONS

Storage Temperature	-40 to 125°C
Operating Temperature	-20 to 115°C
IP Rating	IP40
Humidity	90% non-condensing
Vibration	20 g's @ 50 to 500 CPS
Shock	50 g's @ 11 ms duration

## MECHANICAL SPECIFICATIONS

Bore Diameter (Tolerance)	0.250" (+0.0010/-0.0000")
Allowable Shaft Runout	0.007" TIR
Axial Shaft Movement	$\pm$ 0.030"
Maximum Shaft Speed	8000 RPM
Interface Connector	Connector: JAE P/N FI-W15P-HFE
Mounting	Size 15 pancake resolver
Moment of Inertia	$9.1 \times 10^{-5}$ oz-in-s <sup>2</sup>
Acceleration	$1 \times 10^5$ radians/s <sup>2</sup>
Accuracy	Instrument error 1.5 arc minutes max

## 15 PIN CONNECTOR JAE P/N: FI-W15P-HFE

Pin Number	Function
1	A
2	A'
3	B
4	B'
5	Z
6	Z'
7	U
8	U'*
9	V
10	V'*
11	W
12	W'*
13	Vcc
14	GND
15	NC

\* U', V' and W' are "no connect" for Output option B (open collector UVW)

## ELECTRICAL OUTPUT CIRCUITS

### Output Option A:

ABZ = 26C31 line driver (RS-422)  
UVW = 26C31 line driver (RS-422)

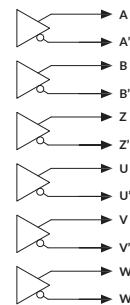

### Output Option B:

ABZ = 26C31 line driver (RS-422)  
UVW = open collector

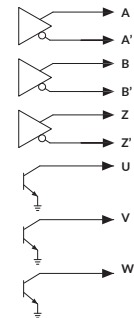

- 26C31 line driver is TTL compatible (can be wired single-ended)
- 26C31 sink/source 20 mA max (meets RS-422 at 5 VDC supply)
- Open collector sink 30 mA max, pull up voltage 30 VDC max
- U, V and W are "no connect" for Commutation option 0

\*Quantum Devices, Inc. reserves the right to make changes in design, specifications and other information at any time without prior notice.

## MOUNTING

Motor resolver pocket to be same depth as motor shaft shoulder used as a mounting stop for the encoder, 0.062" ( $\pm 0.025$ ") below motor rear face.

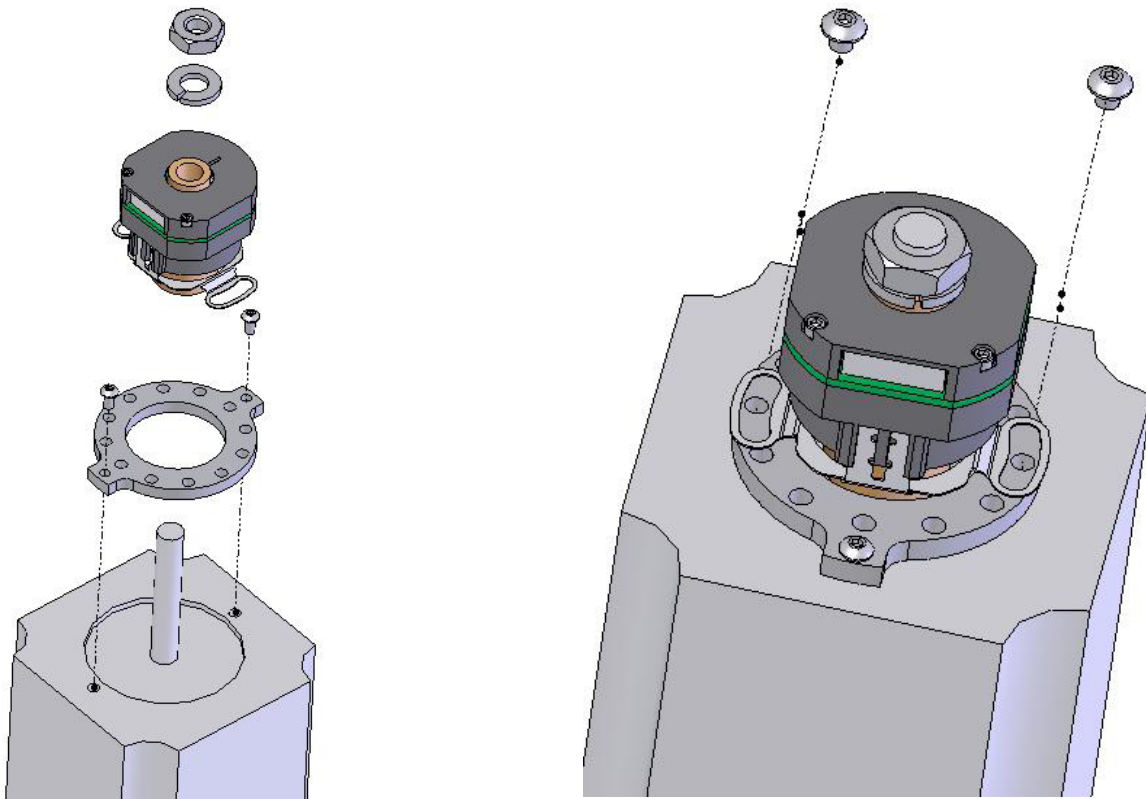

Install resolver adapter with #2-56 socket head screws. Slide encoder over 1/4" threaded shaft and secure with lock washer and jam nut to a torque of 40 to 60 in-lbs. Use thread lock or second jam nut if additional retention is required. Install (2) #4-40 button head screws to encoder flex mount to secure encoder body.

## MECHANICAL DIMENSIONS

### JR12 JAM NUT MOUNT 0.250" BORE

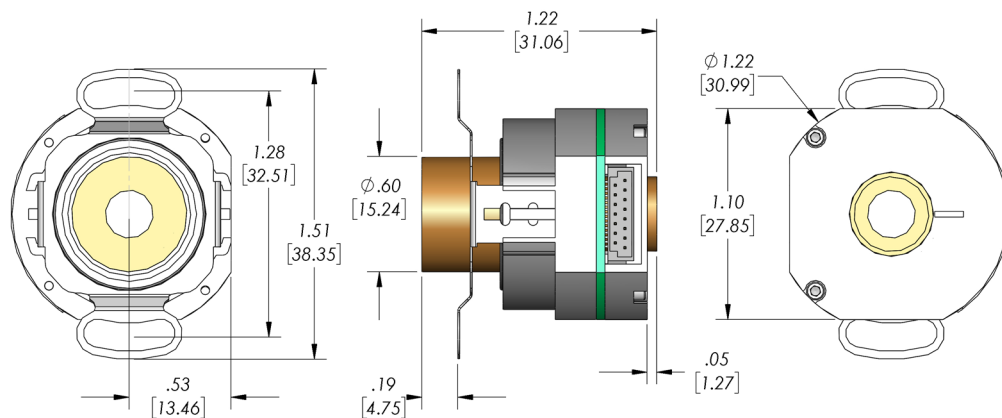

\*Quantum Devices, Inc. reserves the right to make changes in design, specifications and other information at any time without prior notice.

## SIZE 15 RESOLVER MOUNTS

Utilize the optional resolver mount adapters to mate the JR12 to Size 15 Pancake Resolver motor configurations. Eliminate the expensive mounting servo clamps by attaching either the two or three point adapters directly to the servo clamp holes. Assemble the JR12 to the adapter plate using (2) #4-40 screws.

### DIMENSIONS

#### Optional Aluminum Resolver Adapters

2074D024 - Two Point 30 Degree  
Commutation Adjustment Range

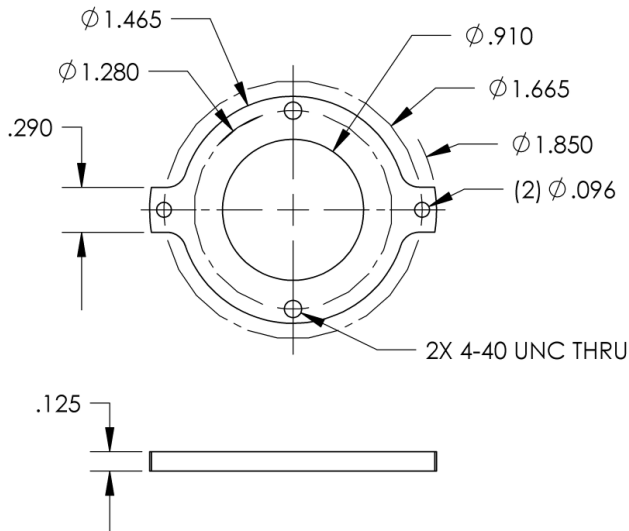

2074D025 - Two Point 360 Degree  
Commutation Adjustment Range

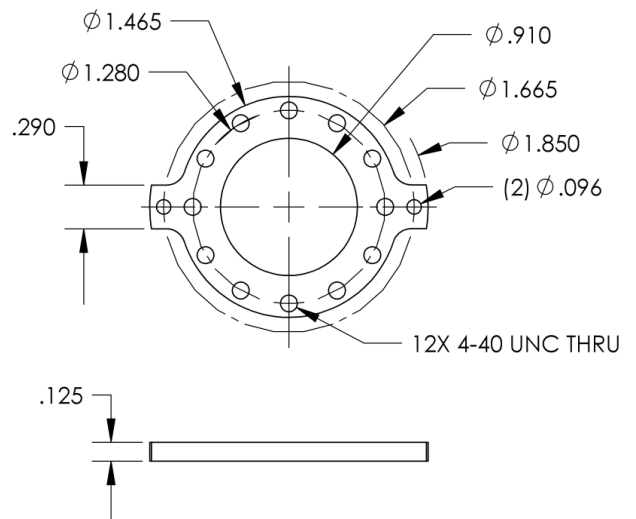

2074D026 - Three Point 30 Degree  
Commutation Adjustment Range

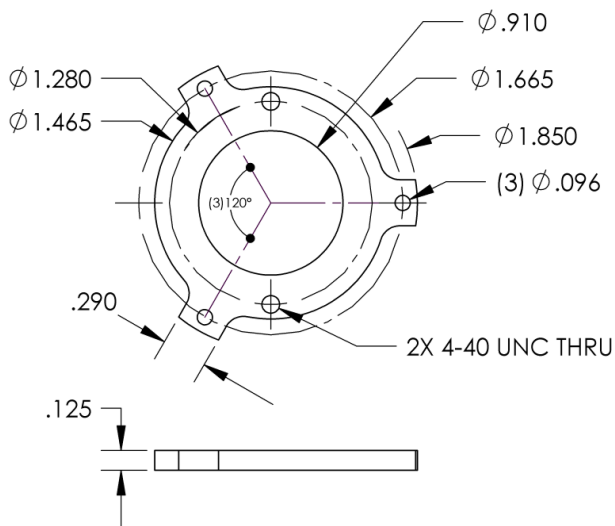

2074D027 - Three Point 360 Degree  
Commutation Adjustment Range

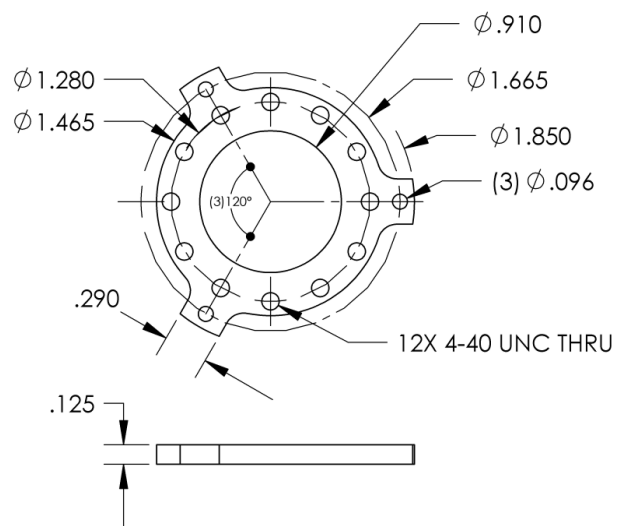

\*Quantum Devices, Inc. reserves the right to make changes in design, specifications and other information at any time without prior notice.

## CABLE ACCESSORIES

(2080AG039, 2082AG039, 2094AG039, 2081AG019, 2083AG019, 2095AG019)

Consult Factory for Custom Lengths

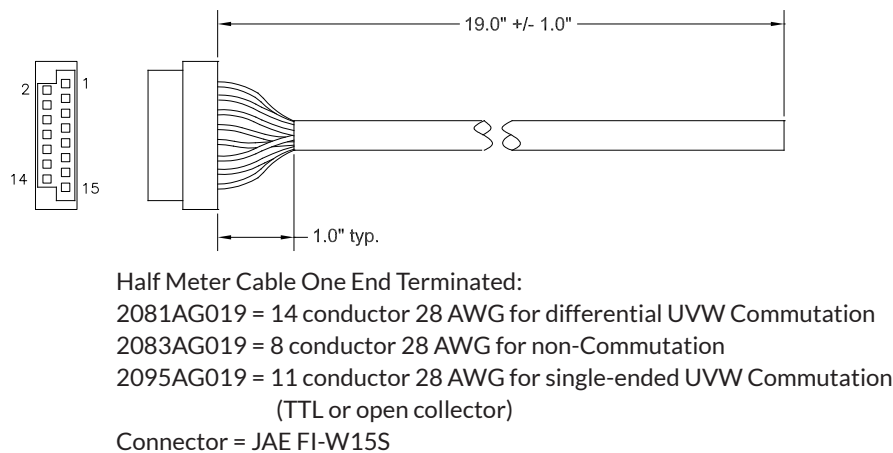
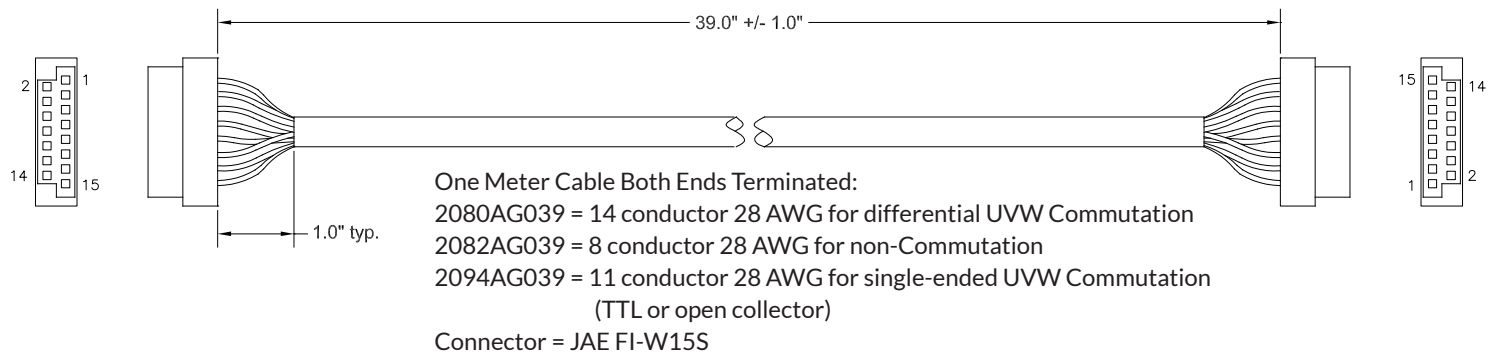

Pin Number	Encoder Pin Function	2080AG039 2081AG019 Wire Color	2082AG039 2083AG019 Wire Color	2094AG039 2095AG019 Wire Color
1	A	Brown	Brown	Brown
2	A'	White	White	White
3	B	Blue	Blue	Blue
4	B'	Green	Green	Green
5	Z	Orange	Orange	Orange
6	Z'	Yellow	Yellow	Yellow
7	U	Violet	-	Violet
8	U'	Gray	-	-
9	V	White/Brown	-	White/Brown
10	V'	White/Red	-	-
11	W	White/Orange	-	White/Orange
12	W'	White/Yellow	-	-
13	Vcc	Red	Red	Red
14	GND	Black	Black	Black
15	No Connect	-	-	-

Note:

1. Cable has internal foil shield with 28 AWG drain wire trimmed to jacket edge
2. Unused wires to be locally isolated from adjacent signal wires, Vcc and GND to prevent damage to encoder signals
3. 2094AG039 and 2095AG019 can be used with Output option A to provide TTL UVW signals

### For brushless motors requiring commutation timing:

- Encoder drawings indicate position of encoder hub to encoder body at Z (index). Rotating the hub to this position allows for known U channel transition state, prior to assembling to motor shaft.
- Power appropriate motor windings to lock motor shaft location to match the appropriate U transition, prior to assembly to motor shaft.
- Flex mount screws can be loosened to allow rotation of encoder body. While mechanically back driving the motor, monitor motor winding EMF position to the powered encoder commutation position. Rotate the encoder body to achieve accurate timing of encoder commutation feedback channels to the appropriate motor winding EMF. Mounting slots in encoder flex mount allow for 30 mechanical degrees of rotation. Re-tighten the flex mount screws.

Additional installation and handling instruction available at: [www.quantumdev.com](http://www.quantumdev.com)

\*Quantum Devices, Inc. reserves the right to make changes in design, specifications and other information at any time without prior notice.

REV. 200618

**ISO 9001**  
CERT. NO. FM 52711