

Photoelectric Sensor S18 series



Precautions

- The maximum allowable voltage of the sensor is 10% of the rated voltage. Please confirm that the supply voltage is less than the maximum allowable value before powering on.
- The time from powering-on to normal detection of the sensor is 100ms. Please ensure that the sensor is used after 100ms of powering-on.
- When using different power sources for the sensor and load, be sure to turn on the power of the sensor first.
- When the sensor is not used, it is recommended to cut off the power of the load first and then turn off the power of the sensor. Avoid using thinner, alcohol or other organic solvents when cleaning.

Safety Warning

- Do not use in an environment with flammable, explosive or corrosive gases.
- Do not use in oil or chemical environments.
- Do not use in a high humidity environment.
- Do not use in direct sunlight.

Accessory Dimensions (Sold separately except the nut)

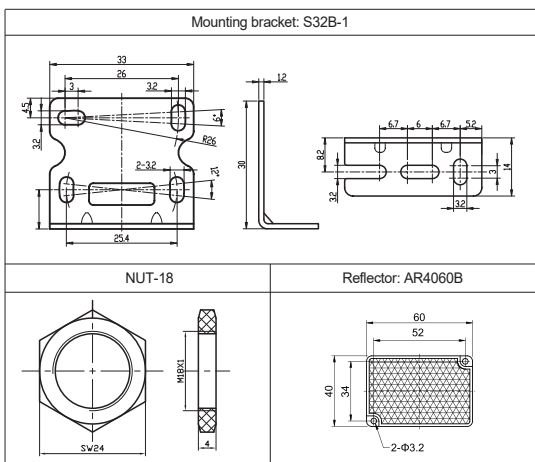

Technical specifications

Detection type		Through beam	Polarized retroreflective	Diffuse	Fixed field BGS	
Part number	NPN cable	Emitter S18TBSLI	Receiver S18TBRNI	S18PR300NR	S18D30NR	S18F10NR
	NPN connector	Emitter S18TBSLIC	Receiver S18TBRNIC	S18PR300NRC	S18D30NRC	S18F10NRC
	PNP cable	Emitter S18TBSLI	Receiver S18TBRPI	S18PR300PR	S18D30PR	S18F10PR
	PNP connector	Emitter S18TBSLIC	Receiver S18TBRPIC	S18PR300PRC	S18D30PRC	S18F10PRC
Sensing distance		0.3...20m	0...3m*	0.5...30cm	10cm	
Light spot		/	180*180mm@3m	18*18mm@30cm	8*8mm@10cm	
Standard target		>φ15mm opaque object				
Hysteresis range		/		3...20%	≤5%	
Direction angle		>4°		/		
Light source		Infrared LED (850nm)		Red LED (660nm)		
NO/NC adjustment		Cable: NO: white wire is connected to positive; NC: white wire is connected to negative Connector: NO: pin 2 is connected to positive; NC: pin 2 is connected to negative				
Supply voltage		10...30 VDC				
Consumption current		Emitter: ≤15mA; Receiver: ≤18mA		≤20mA	≤25mA	
Load current		≤100mA				
Residual voltage		≤1V				≤1.8V
Circuit protection		Short-circuit, overload, reverse polarity and zener protection				
Distance adjustment		Single-turn potentiometer			Non-adjustable	
Response time		≤1ms		≤0.5ms		
Indicator display	Green	Power indicator		Power indicator, stable indicator (blinking means unstable signal)	Power indicator, stable indicator (low brightness, weak signal)	
	Yellow	Output indicator Short circuit or overload indicator (flashing)		Output indicator, short circuit or overload indicator (flashing)	Output indicator short circuit or overload indicator (flashing)	
Anti-ambient light		Anti-ambient light interference < 10,000lux; Incandescent light interference < 3,000lux				
Ambient temperature		-15°C...60°C				
Storage temperature		-25°C...70°C				
Protection degree		IP67				
Certification		CE				
Production standards		EN60947-5-2:2012, IEC60947-5-2:2012				
Installation		Composite installation				
Optical components		Housing material: ABS; Filter: PMMA				
Weight		Connector: 10g; Cable: 52g				
Accessories		NUT-18				

*Range when used with AR4060B reflector for polarized retroreflective sensor.

Wiring Diagram

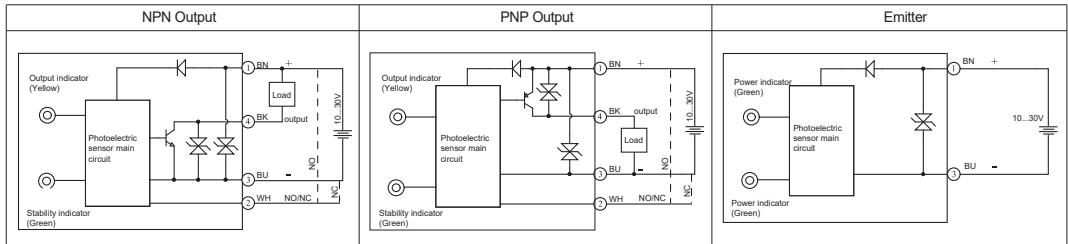

Terminal Wiring Diagram

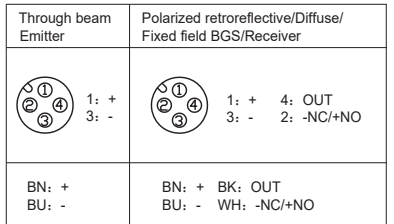

Mounting

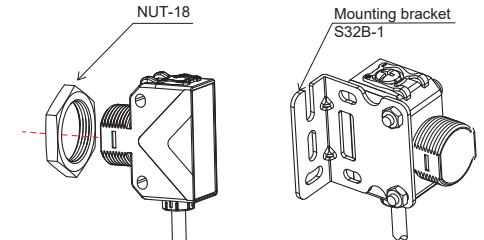

Dimensions

